



# MHT410 Moisture, Hydrogen and Temperature Transmitter

For online transformer condition monitoring



## Features and benefits

- Measures moisture and hydrogen directly in transformer oil
- Compatible with mineral oil, natural ester oil, synthetic ester oil, and silicone oil
- Easy to install
- Provides early warning on potential transformer faults
- Unique probe design allows for direct measurement in oil
- 5-year standard warranty
- Robust design providing reliable operation and no false alarms
- Maintenance-free operation
- No cross-sensitivity to other gases
- Indigo520 compatible, with easy access to measurement data

Vaisala MHT410 Moisture, Hydrogen and Temperature Transmitter provides reliable online monitoring of insulating oil in power transformers.

## Real-time measurement

Vaisala Moisture, Hydrogen and Temperature Transmitter MHT410 provides an accurate real-time measurement result for critical parameters measured in oil, enabling reliable conclusions on the transformer's condition. With its unique probe design, MHT410 delivers accurate measurement and trend data about the health of the transformer in real time.

## Enabling proactive maintenance decisions

All of the transmitter's measured parameters are available through digital and analog outputs, providing information on transformer fault situations and enabling timely, proactive maintenance decisions to minimize expensive service shutdowns and outages.

MHT410 is also compatible with the Vaisala Indigo500 series transmitters. With its local graphical display, Indigo520 is a great addition to MHT410. It helps you to identify data trends at the site, as well as power the MHT410 with a single-wire solution.

## Robust and maintenance-free operation

MHT410 is designed for ease of use in demanding environments. It has undergone extensive testing to ensure it withstands wide temperature changes, vibration, and harsh outdoor conditions. The transmitter has no consumables or moving parts that could break, and is encased in an IP66-rated metal housing equipped with a weather shield.

Every unit is individually tested for a pressure of at least 10 bar and also withstands vacuum conditions. Special attention has been given to EMC tolerance: for example, all electrical connections are isolated. MHT410 can also tolerate short-term power outages.

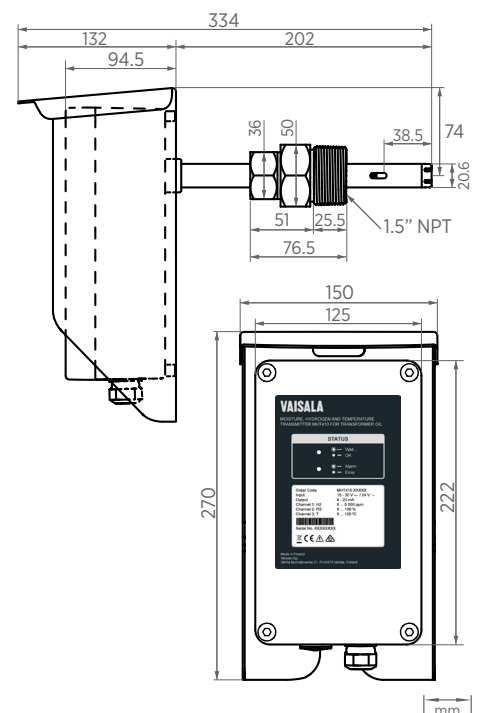

# Technical data

## Measurement performance

### Hydrogen

Measurement range (in oil)	0–5000 ppm <sub>v</sub>
Accuracy <sup>1) 2)</sup>	±10 % of reading or ±15 ppm <sub>v</sub> (whichever is greater)
Repeatability	±10 % of reading or ±15 ppm <sub>v</sub> (whichever is greater)
Minimum detection limit	15 ppm <sub>v</sub>
Typical long-term stability	3 % of reading / year
Cross sensitivity to other gases	< 2 % (CO <sub>2</sub> , C <sub>2</sub> H <sub>2</sub> , C <sub>2</sub> H <sub>4</sub> , CO)
Response time	63 % of full response: 2 h (when sensor is not in reference cycle)
Warm-up time	2 h, 12 h for full specification
Sensor	Catalytic palladium-nickel alloy film solid-state sensor

### Moisture in oil

Measurement range (in oil)	0–100 %RS / a <sub>w</sub> 0–1
Response time (90 % of full response at +20 °C (+68 °F) in still oil)	10 min
Sensor	HUMICAP® 180L2
Accuracy (including non-linearity, hysteresis, and repeatability):	
0–90 %RS	±2 %RS (a <sub>w</sub> ± 0.02)
90–100 %RS	±3 %RS (a <sub>w</sub> ± 0.03)

### Temperature

Measurement range	–40 ... +120 °C (–40 ... +248 °F)
Accuracy at +20 °C (+68 °F)	±0.2 °C (0.36 °F)
Sensor	Pt1000 RTD Class F0.1 IEC 60751

- 1) The H<sub>2</sub> accuracy specified is the accuracy during calibration against gas in oil standard. Field performance may be affected, for example, by variation in hydrogen solubility (partition coefficients) between different mineral oils.  
2) The H<sub>2</sub> accuracy specified is applicable in the oil temperature specified (–20 ... +75 °C (–4 ... +167 °F)).

## Inputs and outputs

Operating voltage	15–30 V DC, 24 V AC (±15 %) (power supply input is galvanically isolated) <sup>1)</sup>
Power consumption	Typical 4 W, maximum 12 W

### Analog output (current) <sup>1)</sup>

Channels	3 isolated 4–20 mA (loop-powering)
External load	Max. 500 Ω
Error status indication in case of device error	3.5 mA default, user-configurable for each channel
mA output accuracy at +20 °C (+68 F)	±0.125 % full scale
Temperature dependence of the analog outputs	±0.006 % / °C full scale

### Digital outputs <sup>1)</sup>

Interfaces	Isolated RS-485 half-duplex RS-485 (Service Port, non-isolated)
Protocols	Modbus® RTU, DNP3, serial ASCII
Screw terminals	Wire size AWG 22-14 Single wire (solid) 1.5 mm <sup>2</sup> Stranded wire (flex.) 1.0 mm <sup>2</sup> Recommended wire torque 0.4 Nm

1) Max. isolation voltage 1.5 kV DC.

## Mechanical specifications

Mechanical connection on transmitter	1.5" NPT (male)
Cable gland (optional, for use with Indigo520)	M20×1.5 for cable diameter 5 ... 9 mm (0.20–0.35 in)
Cable gland (optional)	M20×1.5 for cable diameter 8 ... 11 mm (0.31–0.43 in)
Cable gland (optional)	M20×1.5 for cable diameter 11 ... 14.5 mm (0.43–0.57 in)
Conduit fitting (optional)	1/2" NPT
Interface cable (optional, pre-assembled)	5 m (16 ft 5 in), 9.2 mm (0.36 in) outer diameter
Interface cable (optional)	10 m (33 ft), 9.2 mm (0.36 in) outer diameter
Interface cable (optional, for use with Indigo520)	10 m (33 ft), 6.2 mm (0.24 in) outer diameter
Housing material	AlSi 10 Mg
Transmitter weight without cables	4.1 kg (9.04 lb)
Self-diagnostics indication	Status LEDs, analog output, Modbus
Integrated data logging capabilities	Non-volatile memory, up to 44 years' storage with default logging
Individual functional test reports	Calibration test reports for moisture, hydrogen, and temperature; probe leak test report (5 bara nominal)
Factory warranty	5 years

## Operating environment

Oil type	Mineral oil / Natural ester oil / Synthetic ester oil / Silicone oil
Operating temperature of probe head	–40 ... +120 °C (–40 ... +248 °F)
Operating temperature of enclosure	–40 ... +60 °C (–40 ... +140 °F)
Storage temperature	–40 ... +60 °C (–40 ... +140 °F)
Operating humidity	0–100 %RH, condensing
Pressure tolerance (probe, short-term)	Max. 10 bara
Pressure tolerance (probe, continuous)	Max. 4 bara
Integrated protection for short power outages	> 3 s
IP rating	IP66

## Compliance

EU directives and regulations	EMC, RoHS
Electromagnetic compatibility (EMC)	EN 61326-1, industrial environment CISPR 32 / EN 55032, Class B (when DC powered)
Environmental	ISO 6270-1:2017, constant humidity condensation atmosphere, C5-M ISO 9227:2017, salt fog, C5-M ISO 12994-6, Paints and varnishes — Corrosion protection of steel structures by protective paint systems, part 6, C5
Compliance marks	CE, EAC, RCM, UKCA

**VAISALA**

www.vaisala.com

Published by Vaisala | B211484EN-J © Vaisala 2023

All rights reserved. Any logos and/or product names are trademarks of Vaisala or its individual partners. Any reproduction, transfer, distribution or storage of information contained in this document is strictly prohibited. All specifications — technical included — are subject to change without notice.